



Mottagare: Kontrollanter, kontrollantelever, klubbar, MC Norden	Datum: 2003-09-26	Bilaga SB1/2003/ TECH240	Blad nr: 1 av 1
Fastställt av MK: 2003-09-26	Ersätter:	Ärende: Materielmeddelande nr. 4/03	
		Utfärdare: SFF Materielkommitté (MK)	

Bakgrund

Tidigare i sommar infördes med omedelbar verkan och tills vidare strängare vikts- och fartbegränsningar för reserver av typen Techno 240. Se materielvarning 3/03, daterad 7 juli, för detaljer. Parachutes de France har nu tagit fram ett modifieringspaket som efter installation återställer de ursprungliga begränsningarna på skärmen.

Omfattning

Alla Techno 240 reservfallskärmar tillverkade av Parachutes de France, P/N R01-240-A.

Åtgärd

Installation av modifieringar enligt "Kit Techno 240-B", P/N: P2009052900. Modifieringen innebär byte av slider och nedre delen av styrlinorna samt användande av en ny packmetod. Detaljerade instruktioner finns med i modifieringspaketet.

När

Senast 1 december, 2003.

Notera att Parachutes de France kräver att alla berörda kalotter åtgärdas, dvs. det är inte tillåtet av fortsätta att använda omodifierade kalotter även om man skulle tillämpa de strängare vikts- och fart-begränsningarna.

Kommentar

Uffe's Hopp Shop, som är Parachutes de Frances svenska återförsäljare, meddelar att modifieringspaketet nu finns att få kostnadsfritt mot uppgivande av serienummer på berörda kalotter.

Bilaga

Service-bulletin SB1/2003/TECH240, daterad 28 juli 2003, från Parachutes de France.

TITLE: MAXIMUM OPERATING LIMITS TECHNO 240

Page 5/8

1 Technical background

- a) **Effectivity** : **ALL Techno 240 sq/ft** P/N: **R01-240-A**
218 (Old Part Number)
- b) **Reason** : A control test showed that the maximum operating conditions, (286 lbs for maximum operating weight and 150 kt for maximum pack opening speed) as defined in current applicable regulation, are no longer reached.
- c) **Description** : Slider replacement, steering lines modification, packing modification.
- d) **Compliance** : **-1) Mandatory for any use superior to** the maximum operating limits defined in DGAC Emergency Airworthiness Directive #U2003-263(A):(**220 lbs / 130 Kt**).
-2) Mandatory for any use after 01December 2003
- e) **Approval** : This service bulletin is approved by DGAC, member of JAA.
- f) **Labour** : Qualified riggers or packers.
- g) **Weight and balance** : Non applicable
- h) **Références** : FEE (Equipment Evolution Leaflet) # 217
- i) **Publication affected** : owner's manual for all Techno reserve canopies (Ed 05, Nov 2000, P/N:P9009111400) is cancelled and replaced by owner's manual for Techno 240 (Ed 01, Juil 2003, P/N: P9009111410).
- j) **Interchangeability** : Non applicable.

2 Information about equipment:

- Material** : - Kit Techno 240-B (P/N:P2009052900) X 1, including:
 - P/N: P2008036600: slider 57X74 CR X1
 - P/N: P2009030800: steering lines set Techno 240-B X1
 - P/N: P9009111410: use & maintenance manual Techno 240 X1
- Supplier** : Parachutes de France SA, 2 rue Denis Papin Jouy le Moutier,
 95031 Cergy Pontoise Cedex FRANCE
 Web site: www.Parachutes-de-france.com
 e-mail:infopdf@zodiac.com
 Tel: +33(0)1 34 32 73 77 Fax: +33(0)1 34 32 73 17

3 Accomplishment instructions: According to instructions and drawings (pages 6 to 8).

DISTRIBUTION:
 DGAC-FFP-Military OfficialOffices
 Distributors-Users-GSAC-ARZ

APPROVAL

Date	Name	Visa
07/28/2003	SUZE G. Quality Manager PdF	

STEP A - STEERING LINES REPLACEMENT:

1) et 2) Cut the steering line of canopy at the specified point to remove main steering line from secondary.

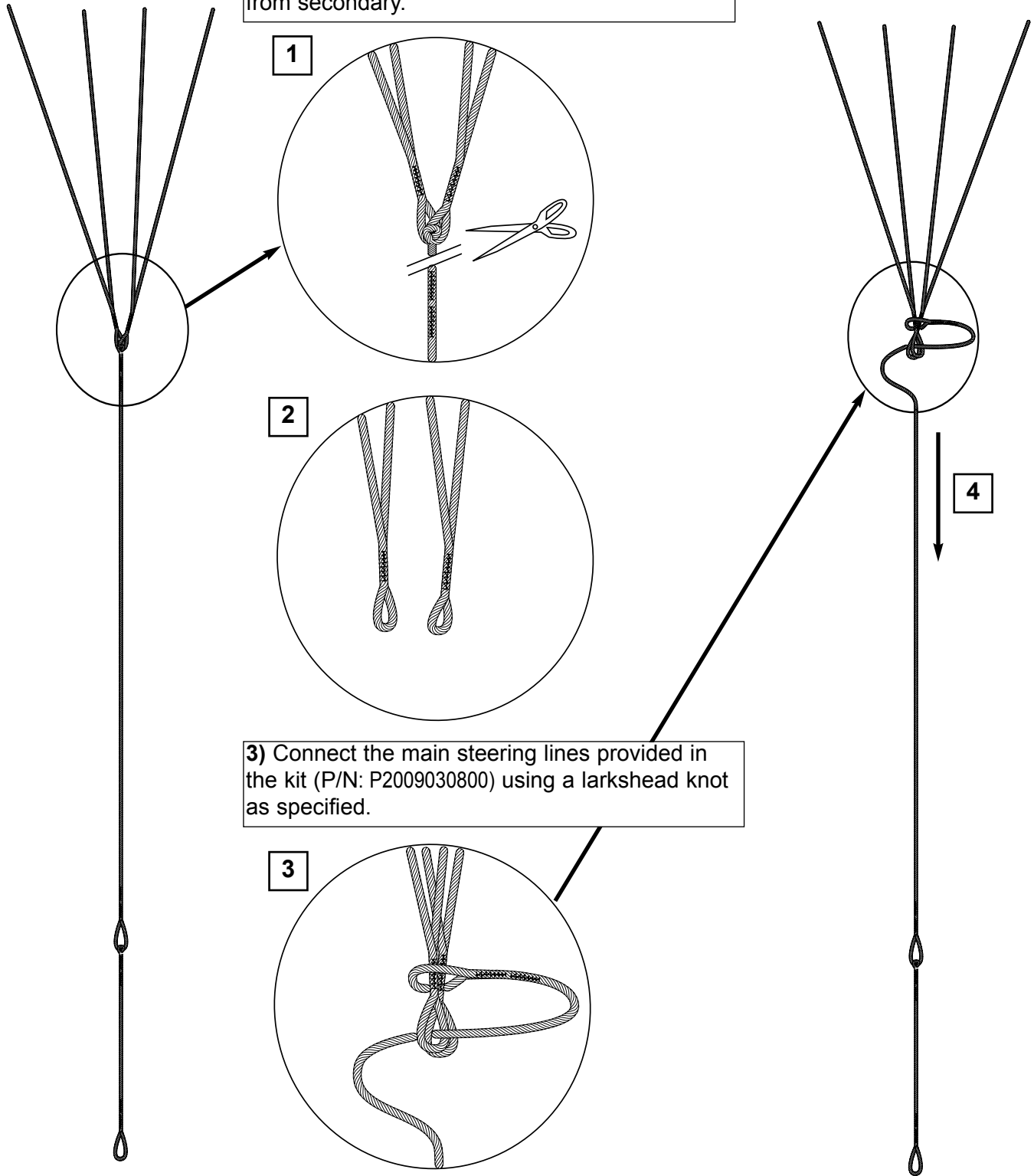

3) Connect the main steering lines provided in the kit (P/N: P2009030800) using a larkshead knot as specified.

4) Hold the larkshead knot tight.
Carry out same operations to the opposite steering line.

CHECK: ensure both steering lines are symmetrical.

STEP B - SLIDER REPLACEMENT:

- 1** Remove the original slider of canopy.
(P/N:P2008040060, identification stamp: 64-42-13)

Install the slider provided in retrofit kit.
(P/Nf: P2008036600, identification stamp: 57-74 CR)

Before installation, the canopy must be inspected and checked.

Installation and packing implies that canopy, its components and accessories are in perfect condition and airworthy.

- 2** Connect the canopy to the rig.

- 3** Check the canopy connection to risers with the following drawings:

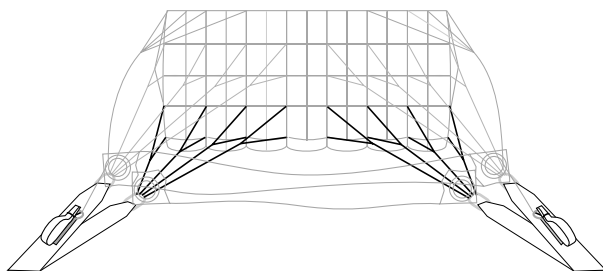

front lines assembling

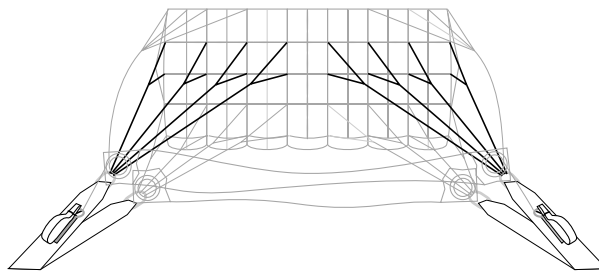

rear lines assembling

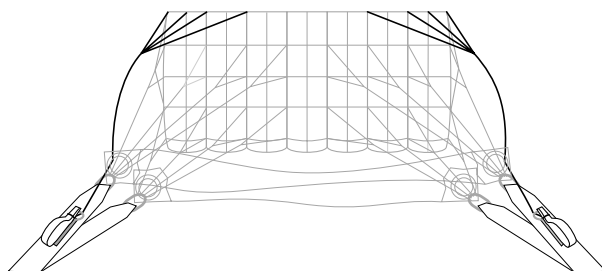

Steering lines assembling

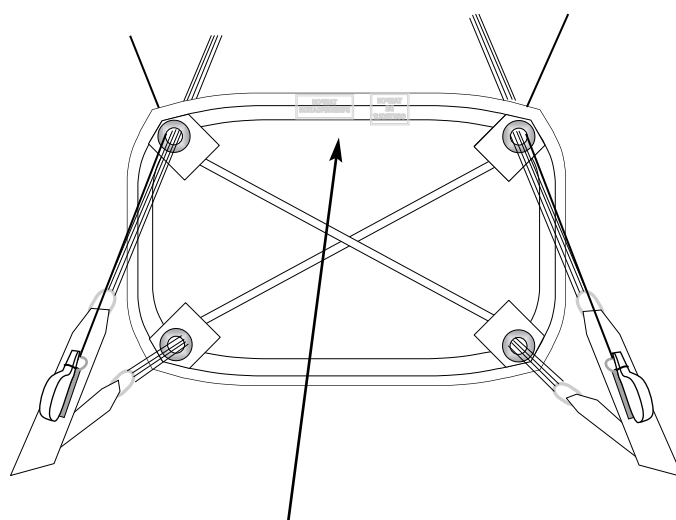

Check of slider position
The identification stamp should be placed between
rear risers toward top direction.
(intrados side)

STEP C - PACKING:

Pack the canopy following the packing stages described in the “use and maintenance manual Techno 240, Edition 01 July 2003” (provided in the kit techno 240-B).

This new packing is a major component of the evolution applied to the canopy to verify the maximum operating limits.

This new manual cancel and replace all precedents issues.

The recommendations of this manual must be applied to all Techno 240 in service.

STEP D - MARKING:



SPORT PARACHUTING IS A HAZARDOUS ACTIVITY THAT CAN RESULT IN INJURY OR DEATH.
 TRAINING AND/OR EXPERIENCE ARE REQUIRED TO LOWER THE RISK OF SERIOUS INJURY OR DEATH. NEVER USE THIS EQUIPMENT UNLESS YOU HAVE READ THIS WARNING LABEL AND COMPLETED A "CONTROLLED PROGRAM OF INSTRUCTION" IN THE USE OF THIS PARACHUTE ASSEMBLY.
A. READ THIS WARNING LABEL AND COMPLETED A "CONTROLLED PROGRAM OF INSTRUCTION" IN THE USE OF THIS PARACHUTE ASSEMBLY.
B. READ WARNING LABEL AND APPROPRIATE OWNERS/FLIGHT MANUALS, PACKING INSTRUCTIONS AND COMPLETED AT LEAST 100 RAM-AIR PARACHUTES TO LOWER THE RISK OF DEATH, SERIOUS INJURY, CANOPY DAMAGE AND HARD OPENING BY NEVER EXCEEDING THE LIMITS SHOWN BELOW:
A. PARACHUTES SOMETIMES MALFUNCTION EVEN WHEN THEY ARE PROPERLY DESIGNED, BUILT, ASSEMBLED, PACKED, MAINTAINED AND USED. EACH MALFUNCTIONS ARE SOMETIMES SERIOUS INJURY OR DEATH.
B. IF YOU USE PARACHUTE OR IF YOU ALLOW SOMEONE ELSE TO USE IT YOU ARE ACKNOWLEDGING SPORT PARACHUTING'S RISK AND ACCEPTING THAT THE PARACHUTE OR ITS COMPONENTS MAY MALFUNCTION.
C. IF YOU ARE NOT WILLING TO ACCEPT THE RISKS OF SPORT PARACHUTING, OR IF YOU AREN'T WILLING TO ACCEPT THE POSSIBILITY THAT YOU OR ITS COMPONENTS MAY MALFUNCTION AND PERHAPS CAUSE YOU TO BE INJURED OR KILLED, THEN YOU SHOULD RECONSIDER YOUR INVOLVEMENT IN SPORT PARACHUTING.
SPORT PARACHUTISTE EST UNE ACTIVITE A RISQUES DONT IL PEUT RESULTER DES BLESSURES OU LA MORT.
 UN ENTRAINEMENT ET/OU UNE EXPERIENCE DU PARACHUTISME SONT INDISPENSABLES POUR REDUIRE LES RISQUES DE BLESSURE GRAVE OU DE MORT. NE PAS MAIS UTILISER CET EQUIPEMENT AVANT D'AVOIR: A. LU ET COMPRIS CET AVERTISSEMENT ET SUIVI UN PROGRAMME D'INSTRUCTION SPECIFIQUE, B. LITRENIENUS ET UTILISES. LES CONSEQUENCES DE TELS DISFONCTIONNEMENTS PEUVENT ENTRAINER LA MORT. C. SI VOUS N'ACCEPTEZ PAS LA POSSIBILITE QUE VOTRE PARACHUTE OU SES COMPOSANTS PUISSENT DISFONCTIONNER, VOUS DEVEZ ALORS RECONSIDERER VOTRE IMPLICATION DANS LE SPORT PARACHUTISTE.

1

Identify the compliance of canopy to the present service bulletin by modification of the P/N inscription on marking label located on the center trailing edge:

**Replace
 "R01-240-A" (or 218)
 by
 "R01-240-B"**

MODEL TECHNO (218)	DATE OF
PN R 01-240-A B	SERIAL
MAX. EMPLOYMENT SPEED	
Vitesse maximum d'utilisation	

2 The packing data card must be annotated to show compliance with the present service bulletin "#SB1/2003/TECH240"